

RDM1 Series

Moulded Case Circuit Breaker



Application

RDM1 series product has small volume, high breaking capacity, short arc, anti vibration advantages, which is the ideal product for land and marine use. Breaker rated insulation voltage 800V (RDM1-63 insulation voltage is 500V), is applied to distribution network of AC 50Hz/ AC60Hz, Rated working voltage up to 690V, rated current up to 1250A to distribute the power and protect the circuit and power source against overload, short-circuit and under-voltage damage, and it also can be used to transfer circuit, motor-start unfrequently and overload, short-circuit and under-voltage protection. The product can be installed vertically and horizontally.

This production is applied to insulation, Sign: 

RDM1 Series

Moulded Case Circuit Breaker

Model No.

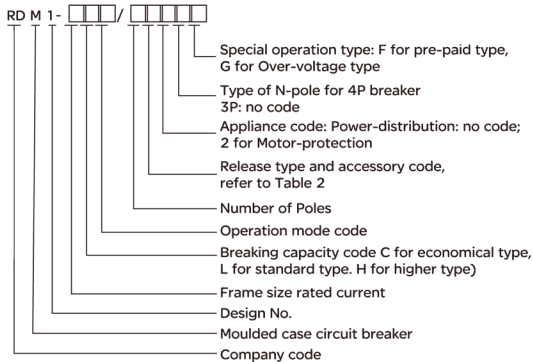

Normal working condition and Installation environment

3.1 Temperature: no higher than +40 °C, and no lower than -5 °C ,and the average temperature no higher than +35°C.

3.2 Installation location no more than 2000m.

3.3 The relative humidity: no more than 50%, when Temperature is +40°C. The product can withstand the higher humidity under lower temperature, for instance, when temperature at +20°C, the product can withstand 90% relative humidity. The condensation that happened because of temperature changes should be taken care in special measurements

3.4 Class of pollution : 3 Class

3.5 Maximum install inclined Angle : 22.5°

3.6 Auxiliary circuit and control circuit installation type : II Class; Main circuit breaker installation type : III Class;

3.7 It can stand the normal vibration and operate stably under marine condition.

RDM1 Series

Moulded Case Circuit Breaker

Table 1 4P with N-pole type.

Code	Structure description(Production without indicated is B type)
A type	N-pole without overload tripping, and N-pole is always connected
B type	N-pole without overload tripping, and connecting, breaking with other poles.

Table 2 Tripping type and accessory code

Accessory code Tripping mode	Accessory name															
	Non	Alarm contact	Shunt release	Auxiliary contact	under voltage release	Shunt release Auxiliary contact	Shunt release + under voltage release	Two sets auxiliary contact	Auxiliary contact + under voltage release	Alarm contact Shunt release	Alarm contact + Auxiliary contact	Alarm contact + under voltage release	Alarm contact + Auxiliary contact + Shunt release	Two sets auxiliary contact + Alarm contact	Alarm contact + under voltage release + Auxiliary contact	
Instantaneous release	200	208	210	220	230	240	250	260	270	218	228	238	248	268	278	
Double release	300	308	310	320	330	340	350	360	370	318	328	338	348	368	378	

Main technical parameter

4.1 Main technical parameter see Table 3

Table 3

Model No.	Frame size rated current Inm A	Rated current In(A)	Rated working voltage Ue(V)	Poles	Rated short-circuit circuit breaker (kA)				Arc distance (mm)
					Icu/cosφ		Ics/cos φ		
					400V	690V	400V	690V	
RDM1-63L	63	(6),10,16,20,25,32,40,50,63	400	3	25	-	12.5	-	≤50
RDM1-63M			400	3,4	50	-	25	-	
RDM1-63H			400	3	50	-	25	-	
RDM1-125L	125	(10),16,20,25,32,40,50,63,80,100,125	400	2,3,4	35	-	25	-	≤50
RDM1-125M			400/690	2,3,4	50	10	35	5	
RDM1-125H			400/690	3,4	85	20	50	10	
RDM1-250L	250	100,125,160,180,200,225,250	400	2,3,4	35	-	25	-	≤50
RDM1-250M			400/690	2,3,4	50	10	35	5	
RDM1-250H			400/690	3,4	85	10	50	5	

RDM1 Series

Moulded Case Circuit Breaker

Table 3

Model No.	Frame size rated current I_n (A)	Rated current I_n (A)	Rated operated voltage U_e (V)	Poles	Rated short-circuit circuit breaker (kA)				Arc distance (mm)
					$I_{cu}/\cos\phi$		$I_{cs}/\cos\phi$		
					400V	690V	400V	690V	
RDM1-400C	400	225,250,315,350,400	400	3	50	-	35	-	≤ 100
RDM1-400L			400/690	3,4	50	10	35	5	
RDM1-400M			400/690	3,4	65	10	42	5	
RDM1-400H			400/690	3,4	100	10	65	5	
RDM1-630L	630	400,500,630	400	3,4	50	-	25	-	≤ 100
RDM1-630M			400/690	3,4	65	10	32.5	5	
RDM1-630H			400	3,4	100	-	60	-	
RDM1-800M	800	630,700,800	400/690	3,4	75	20	50	10	≤ 100
RDM1-800H			400	3,4	100	-	65	-	
RDM1-1250M			1250	700,800,1000,1250	400/690	3,4	65	20	

4.2 Overload current release consists of Thermal relay release with inverse time characteristic and Instantaneous release(electmagnetic).

Table 4

Distribution circuit breaker				Motor-protection circuit breaker			
Rated current I_n (A)	Thermal relay release		Electromagnetic release operational current (A)	Rated current I_n (A)	Thermal relay release		Electromagnetic release operations current (A)
	1.05 I_n Conventional non tripping time H(cold state)	1.30 I_n Conventional tripping time H(Heat state)			1.0 I_n Conventional non-tripping time H (cold state)	1.2 I_n Conventional tripping time H (heat state)	
$10 \leq I_n \leq 63$	1	1	$10I_n \pm 20\%$	$10 \leq I_n \leq 630$	2	2	$12I_n \pm 20\%$
$63 < I_n \leq 100$	2	2					
$100 < I_n \leq 800$	2	2	$5I_n \pm 20\%, 10I_n \pm 20\%$				

RDM1 Series

Moulded Case Circuit Breaker

Circuit breaker accessory

5.1 Internal accessory

5.1.1 Shunt release

Connection diagram, see Fig 1 an Fig 2.

Rated voltage of control power supply: AC 50/60Hz, 230V, 400V; DC24V, circuit breaker can operate reliably under 85% to 110% of the rated control power supply voltage.

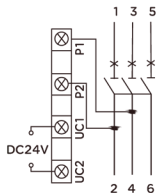

Fig 1 DC 24V connection diagram

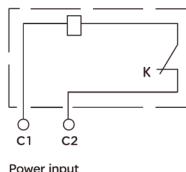

Fig 2 AC 50/60Hz, 230V, 400V connection diagram

5.1.2 Under-voltage release

When the voltage is below 35% of the rated control power voltage, this release can prevent circuit breaker against closing.

Connection diagram, see Fig 3.

When the voltage decrease to the range of 70% to 35% of rated control power voltage, the under-voltage release would trip.

When the voltage is in the range of 85% to 110% of the rated control power voltage, this release can ensure the circuit closing reliably.

Note: The circuit breaker with under-voltage release could trip and close, only supplied the circuit breaker with rated voltage.

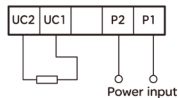

Fig 3 Under-voltage release connection diagram

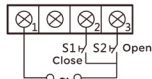

Fig 4 Electric operation mechanism connection diagram

RDM1 Series

Moulded Case Circuit Breaker

5.13 Auxiliary contact

circuit breaker has two sets contact,each set is not open on electric, the auxiliary contact details, see Table 5.

Circuit breaker "open" position		Frame rated current 400A and above
		Frame rated current 250A and below
Circuit breaker "open" positon	"open", contact which is close state turns to open state, contact which is open state turns to close state.	

5.14 Alarm contact

Rated operational voltage's parameter, see Table 5.

When circuit breaker at "open" and "close" position.	
When circuit breaker at "trip free" alarm position	B11,B12 close state turns to open state B11,B14 open state turns to close state

Table 5.

Type	Frame size rated current	AC-15			DC-13		
		Conventional heating current A	Rated operational voltage V	Rated frequency Hz	Rated current A	Rated operational voltage V	Rated current A
Auxiliary contact	$I_{nm} \leq 250$	3	400	50	0.3	230	0.15
	$I_{nm} \geq 400$	3			0.4		0.15
Alarm contact	$63 \leq I_{nm} \leq 800$	3			0.3		0.15

RDM1 Series

Moulded Case Circuit Breaker

5.15 Special circuit breaker accessories of Pre-paid meter

Shunt release of Pre-paid Meter rated operational voltage is AC230V 50Hz, Operate in the range of 65% to 110% U_e , when the Ctrl point is open, circuit breaker will be break after 0.5s to 2s delay. See Diagram:

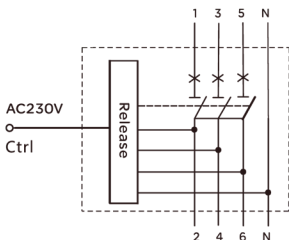

Special circuit breaker for pre-paid meter diagram

5.16 Over-voltage circuit breaker

Over-voltage circuit breaker should be tripping under following conditions:

- When the rated operational voltage(phase voltage) U_e lower than 262V
- When the neutral line of three phases and four wires is breaking
- When the neutral line misconnecting phase lines,

5.2 circuit breaker extranal accessory

5.21 Electric operation mechanism structure see Table 6

Table6

Type	Model	RDM1-63,100,250	RDM1-400,630,800
Structure		Electricmagnetism	Motor
Specification		50Hz,230V,400V	

5.22 Manual operating mechanism should be installed after drilling the hole according to the diagram.

Rotary handle "OFF" indicated to horizontal position, keep the handle position, and try to operating the handle, the rotation should flexible, and the breaker should be open when the handle at horizontal position; and breaker should be closed when the handle at vertical position.

RDM1 Series

Moulded Case Circuit Breaker

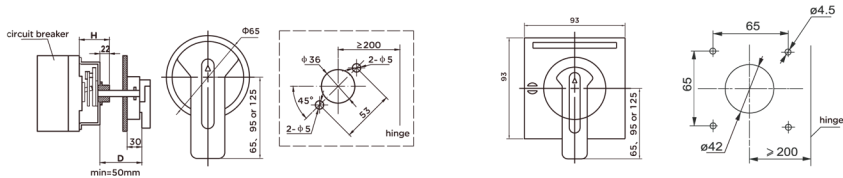

Round extension rotary handle hole size diagram

Square extension rotary handle hole size diagram

Table7(mm)

Model No.	RDM1-63	RDM1-100	RDM1-250	RDM1-400	RDM1-630	RDM1-800
Installation dimension	50	52	54	97	97	90
Y value of the operating handle relative to the breaker Center	0	0	0	0	0	0

5.23 Installation dimension of Mechanical interlock of two circuit breakers, see Table 6 Fig 6 and Table 8.

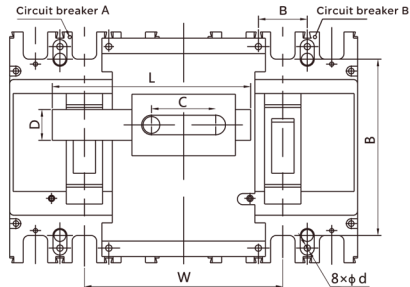

Fig 6 Mechanical interlock dimension diagram

RDM1 Series

Moulded Case Circuit Breaker

Table8(mm)

Model No.	A	B	W	C	L	A	ϕd
RDM1-63	25	117	105	35	22	117	3.5
RDM1-125	30	129	120	46	22	140	4.5
RDM1-250	35	126	138	46	22	132	5.5
RDM1-400L,M,H	44	194	178.5	56	28	188	7
RDM1-800	44	215	176	56	28	188	5.5
RDM1-630	58	200	230	56	28	240	7
RDM1-400C	70	243	250	56	28	252	5.5

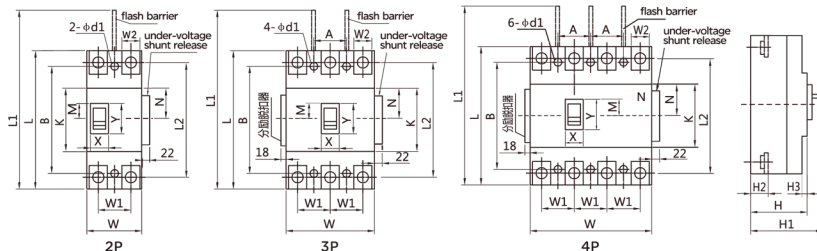

Fig 7 RDM1-63-800 Front connection overall and installation dimension

Table9

Model No.	Front connection overall																Installation dimension					
	W		L	H	H1	H2	H3	W1	L1	L2	W2	K	N	M		X		Y		A	B	ϕd
	3P	4P												3P	4P	3P	4P					
RDM1-63L	76	-	135	73	90.5	20	6.5	25	170	117	14	86.5	42.5	35	-	25	-	69	-	25	117	4
RDM1-63M RDM1-63H	76	102	135	82	98.5	28	6.5	25	170	117	14	86.5	41.5	35	26.5	25	23	69	49	25	117	4
RDM1-125L	92	122	150	68	86	24	7.5	30	200	132	17	89	43	32	27	27	23	67	51	30	129	4
RDM1-125M RDM1-125H	92	122	150	86	104	24	7.5	30	200	132	17	89	43	32	27	27	23	67	51	30	129	4
RDM1-250L	107	142	165	86	110	24	6	35	230	144	24	98	51	39	27	27	23	80	54	35	126	5

RDM1 Series

Moulded Case Circuit Breaker

Table9

Model No.	Front connection overall														Installation dimension							
	W		L	H	H1	H2	H3	W1	L1	L2	W2	K	N	M		X		Y		A	B	φd
	3P	4P												3P	4P	3P	4P	3P	4P			
RDM1-250M RDM1-250H	107	142	165	103	127	24	6	35	230	144	24	102	51	39	27	27	23	80	54	35	126	5
RDM1-400C	140	-	257	100	146	36.5	7.5	44	361.5	225	-	128	50.5	20	-	53	-	90	-	44	215	6.5
RDM1-400L	150	198	257	107	155	38	5	48	357	224	31	128	64.5	48	48	66	66	90	90	44	194	7
RDM1-400M RDM1-400H	150	198	257	107	155	38	5	48	357	224	31	128	64.5	48	48	66	66	90	90	44	194	7
RDM1-630L	182	240	270	112	160	45	3.5	58	370	234	41	135	67.5	45	45	66	66	90	90	58	200	7
RDM1-630M RDM1-630H	182	240	270	114	160	43	3.5	58	370	234	41	138	69	45	42.5	69	67	96	90	58	200	7
RDM1-800M RDM1-800H	210	280	280	117	160	42	5	70	380	243	44	136	65.5	48	48	67	67	82	82	70	243	7.5

6.2 Back connection overall dimension, see Fig 8 and Table 10.

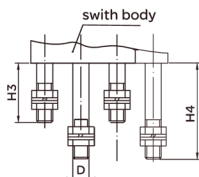

RDM1-63, 125, 250 back connection

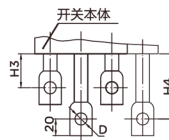

RDM1-400, 630, 800 back connection

Fig 8 RDM1-63-800 Back connection overall and installation dimension

RDM1 Series

Moulded Case Circuit Breaker

6.3 Back connection installation open hole dimension, see Table 9

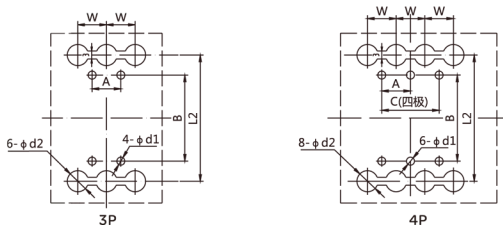

Table 9 RDM1 back connection open hole dimension

Table 10

Model No.	Dimension code.									
	H3	H4	D	W	L2	φd2	A	B	C	φd1
RDM1-63	28	46	M5	25	117	8	25	117	50	5.5
RDM1-125	64	100	M8	30	132	24	30	129	60	5.5
RDM1-250	70	100	M10	35	144	26	35	126	70	5.5
RDM1-400	71	105.5	φ12	48	224	32	44	194	94	7
RDM1-400C	71	105.5	φ10	44	225	32	44	215	-	8.5
RDM1-630	46	105	φ16	58	234	37	58	200	116	7
RDM1-800	105	105		70	243	48	70	243	70	7.5

6.4 RDM1 Insert type's overall and installation open hole dimension, see Fig 10, Fig 11 and Table 11

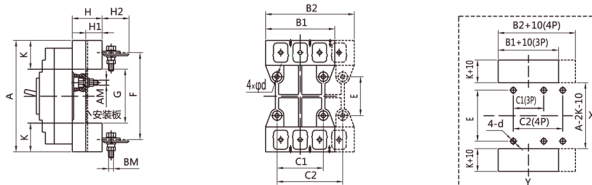

Fig RDM1 Insert type overall and installation open hole diagram

RDM1 Series

Moulded Case Circuit Breaker

Table 11

Model No.	Dimension code.														
	A	B1	B2	C1	C2	E	F	G	K	H	H1	H2	AM	BM	4-d
RDM1-63	135	75	100	50	75	60	117	100	17.5	27.5	18	16	M5	M5	φ5.5
RDM1-125	168	91	125	60	90	56	132	92	38	50	33	28	M6	M8	φ6.5
RDM1-250	186	107	145	70	105	54	145	94	46	50	33	37	M6	M8	φ6.5
RDM1-400	280	149	200	60	108	129	224	170	55	60	38	46	M8	M12	φ8.5
RDM1-630	280	144	-	88	-	143	224	180	50	60	38	48	M8	M12	φ9
RDM1-800	300	182	242	100	158	123	234	170	65	60	39	50	M8	M12	φ8.5
RDM1-400C	305	210	280	90	162	146	242	181	62	87	60	22	M10	M14	φ11

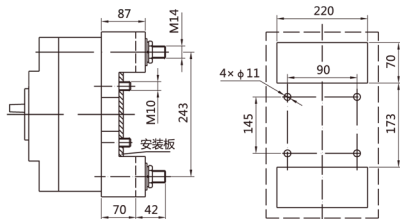

Fig 11 RDM1-800 3P Insert type overall and installation open hole diagram

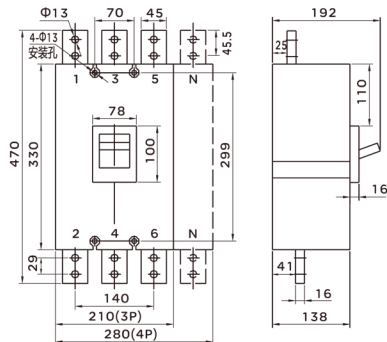

Fig 12 RDM1-125M circuit breaker overall and installation dimension

RDM1 Series

Moulded Case Circuit Breaker

6.5 RDM1 circuit breaker's height after installing motop operating mechanism, see Table 12.

Table12

Model No. Height	RDM1-63L	RDM1-63M RDM1-63H	RDM1-100L	RDM1-100M RDM1-100H	RDM1-250L	RDM1-250M RDM1-250H
AC	155	164	152	170	182	199
DC	160	171	153	171	177	194

Model No. Height	RDM1-400C	RDM1-400L, M, H	RDM1-630L	RDM1-630M RDM1-630H	RDM1-800M RDM1-800H
AC	227	238	246	246	247
DC	160	255	262	262	261